

FEEDBACK SPORTS

PRODUCT MANUAL FOR:

RAKK XL [Bicycle Storage Stand]

DE: Für mehrsprachige Anleitung finden Sie www.feedbacksports.com/product/rakk-xl-bike-storage/

FR: Pour obtenir des instructions multilingues s'il vous plaît visitez feedbacksports.com/product/rakk-xl-bike-storage/

ESP: Para obtener instrucciones multilingües visite feedbacksports.com/product/rakk-xl-bike-storage/

SPECIFICATIONS

Dimensions: 12" X 13.5" X 15" (30.5cm X 34.3cm X 38.1cm)
Capacity: 27.5+, 29+ and fat bikes. 2.3"-5.0" tires.

3-YEAR WARRANTY

Visit: www.feedbacksports.com/warranty/ for more information.

A: Base
B: Foot Cap
C: Snap Button
D: Pulley Arm

E: Half Pulley
F: Pulley Spacer
G: Joining Clip
H: XL Adapter

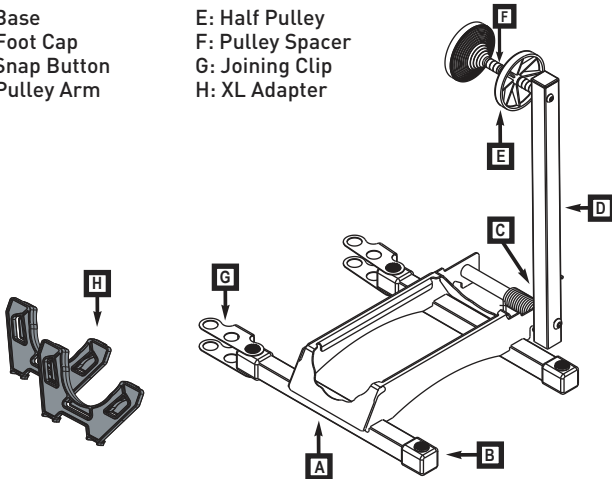

SERVICE PARTS

#17355: RAKK XL Adapter (H)
#13179: RAKK Foot Cap (B)
#13181: RAKK Joining Clip (G)

#13180: Snap Button (C)
#13175: Half Pulley (E)

SET UP_STEP 1_OPEN PULLEY ARM

1. Depress Snap Button (C) to open the Pulley Arm (D).

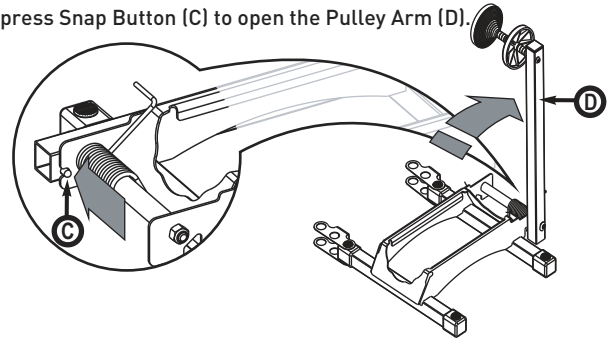

SET UP_STEP 2_INSTALLING PULLEY SPACERS

1. Add Pulley Spacers (F) to reach the desired tire width.

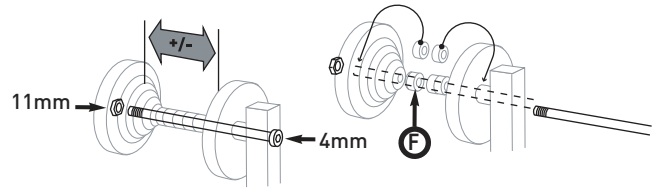

SET UP_STEP 3_INSTALLING XL ADAPTERS

Without Adapters
3"-5"



With Adapters
2.3"-3"

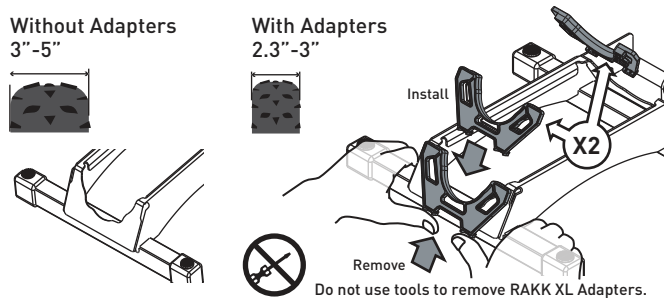

SET UP_STEP 4_CONNECTING RAKKS

1. Connect Multiple RAKKs using the Joining Clips. (G) (FIG.1)

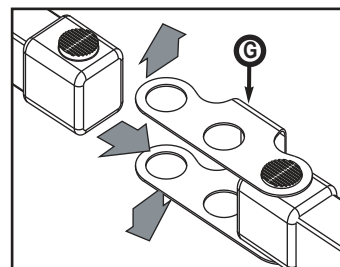

FIG. 1

