

# RAKK STORAGE STAND

## FEATURES



- A: Wheel Stabilizer
- B: Swing Arm
- C: Lock Button
- D: Spring
- E: Wheel Cradle
- F: Pivot Clips
- G: Leg Cap



# BICYCLE & THE STAND

## SET UP & PLACING BICYCLE IN THE STAND

1. Place hand on Swing Arm and press against spring tension. Push the Lock Arm button at the back of the stand and raise the Swing Arm into position.
2. Roll the bike tire straight into the stand until it rests in the bottom of the Wheel Cradle.



**NOTE:** Tire must be inflated to prevent bike from falling over.

# LINKING STANDS

## SETTING UP MULTIPLE STANDS

FIGURE 2  
 1. Adjust the Pivot Clip [F] to desired angle for configuration. (Line, Small Circle and Large Oval set-up shown below)

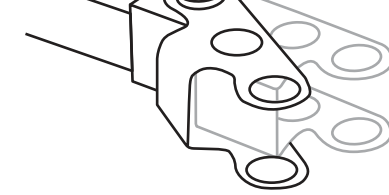

2. With a flat-head screwdriver, guide the clip over the Leg Cap as you connect the stands.

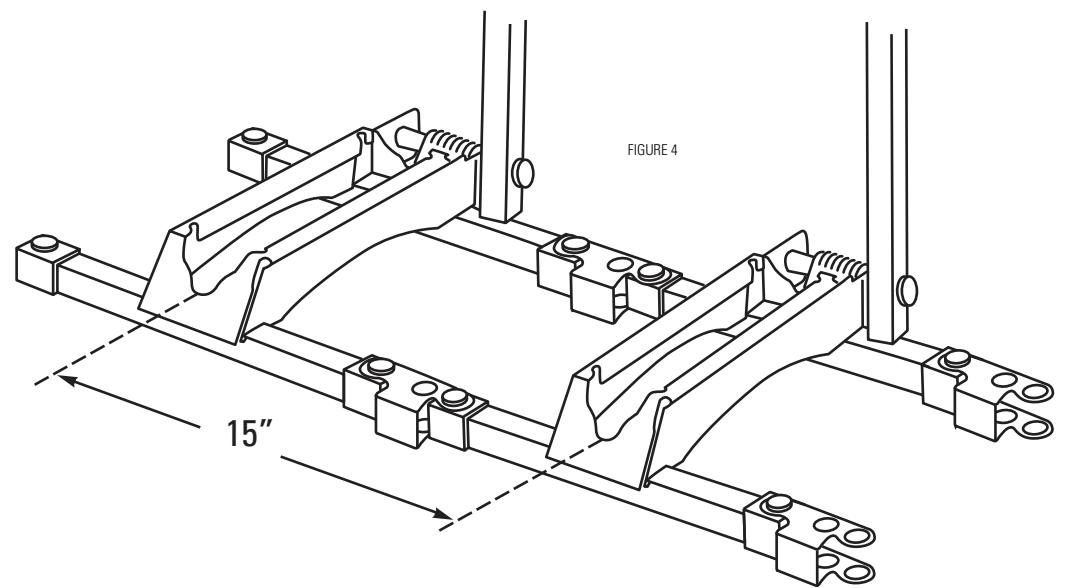
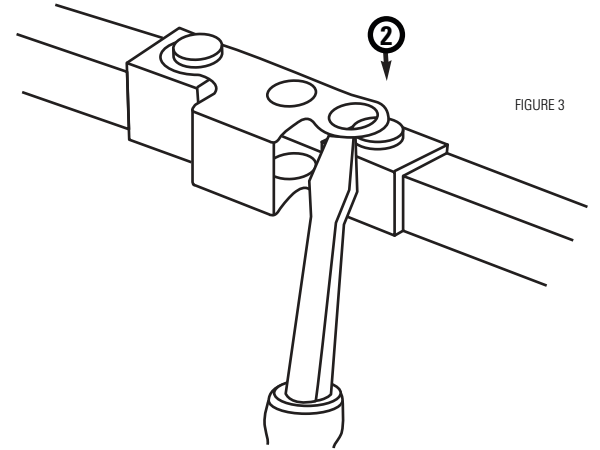

**NOTE:** The different holes on the Pivot Clip allow spacing options of 12", 13.5" and 15".

## SAMPLE CONFIGURATIONS

